

B

C

E

公差表

REV	ECN NO	LOCATIONS	DESCRIPTION	DATE	CHANGER
A			新版本	2016-06-03	李国常

4

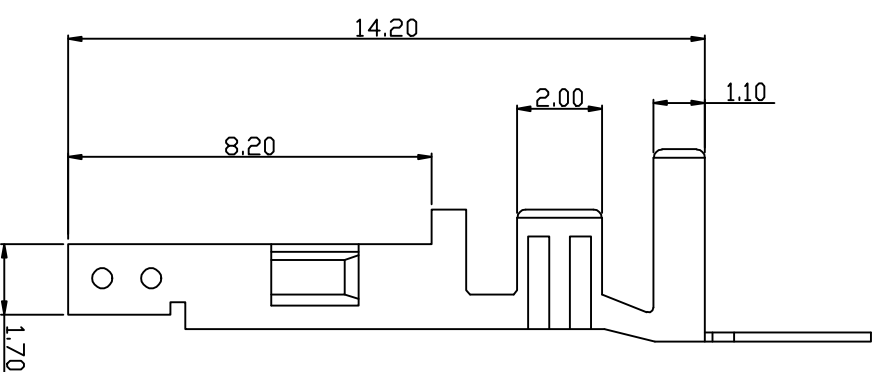
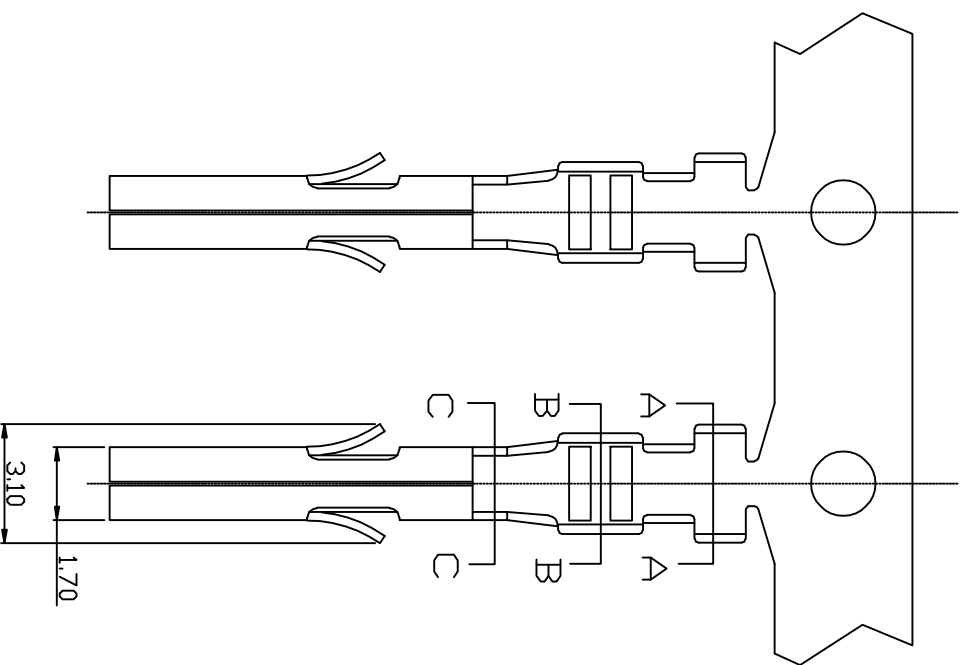

- SPECIFICATIONS
- Voltage rating: 250V AC, DC
 - Current rating: 7A, AC, DC
 - Withstanding Voltage: 1500V AC/minute
 - Insulation resistance: 1000MΩ min
 - Temperature range: -40℃~+85℃
 - Contact resistance: 10MΩ max
- TERMINAL
- Part No: T4202BT
 - Applicable wire: AWG#18-#24
 - Material: Brass
 - Finish: Tin plated

4

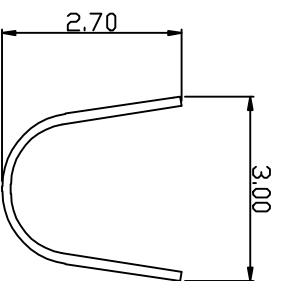

SEC: A-A

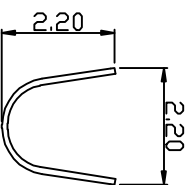

SEC: B-B

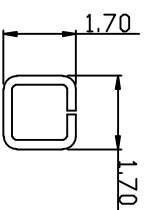

SEC: C-C

KLT 深圳市康利通电子科技有限公司

成品规格图

Tolerance

0±0.30

.0±0.25

.00±0.20

.000±0.015

1

TITLE	DATE	SCALE	VER No	SIZE
CHECKED BY	2016-06-03	1:1		
DRAWN BY	UNIT:mm		A	A4
李国常	PART No	T4202BT		

B

C

D

E

F

B

C

E

公差表

REV	ECN NO	LOCATIONS	DESCRIPTION	DATE	CHANGER
A			新版本	2016-06-03	李国常

■ SPECIFICATIONS

- Voltage rating: 250V AC, DC
- Current rating: 7A, AC, DC
- Withstanding Voltage: 1500V AC/minute
- Insulation resistance: 1000MΩ min
- Temperature range: -40℃~+85℃
- Contact resistance: 10MΩ max

■ HOUSING

- Part No: H4201-NP
- Poles: 02-12
- Material: Nylon 66 UL94V-2

4

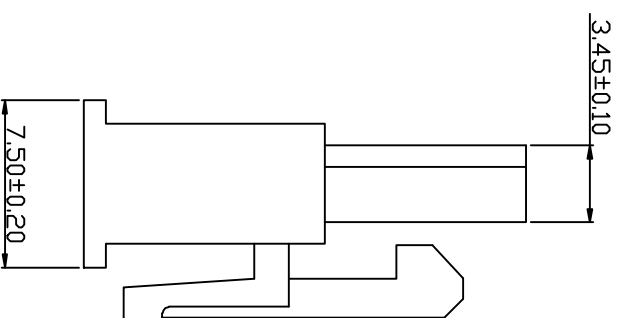
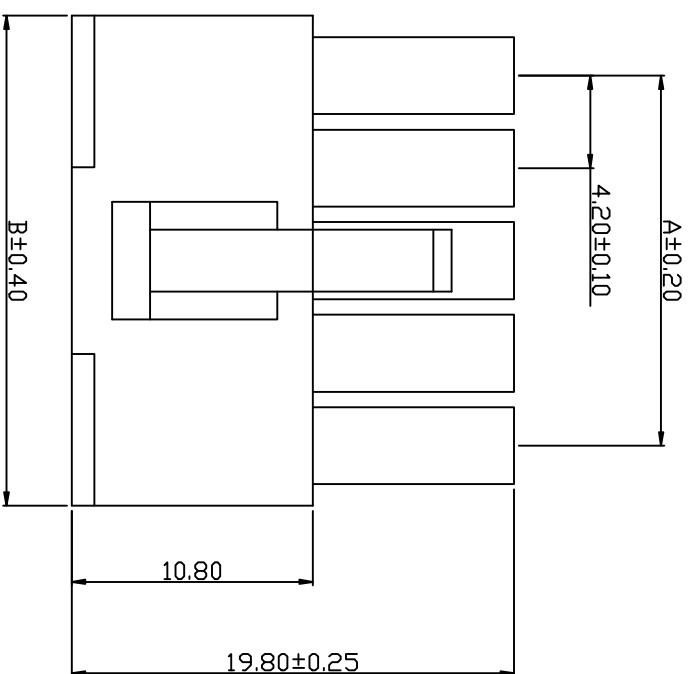

Part No	Dimensions (mm)	
	A	B
H4201-02	4.20	9.60
H4201-03	8.40	13.80
H4201-04	12.60	18.00
H4201-05	16.80	22.20
H4201-06	21.00	26.40
H4201-07	25.20	30.60
H4201-08	29.40	34.80
H4201-09	33.60	39.00
H4201-10	37.80	43.20
H4201-11	42.00	47.40
H4201-12	46.20	51.60

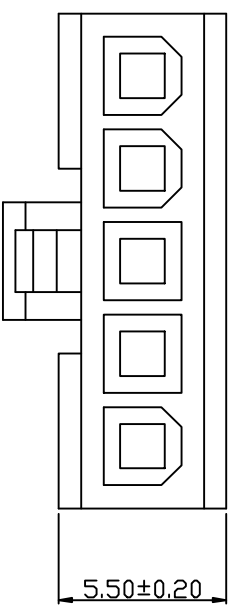

KLT 深圳市康利通电子科技有限公司

成品规格图

TOLERANCE

- 0±0.30
- .0±0.25
- .00±0.20
- .000±0.015

1

4

TITLE	成品规格图		TOLERANCE	
CHECKED BY	DATE	SCALE	VER No	SIZE
	2016-06-03	1:1	A	A4
DRAWN BY	UNIT:mm			
李国常	PART No	H4201-NP		

B

C

D

E

F

B

C

E

公差表

REV	ECN NO	LOCATIONS	DESCRIPTION	DATE	CHANGER
A			新版本	2016-06-03	李国常

■ SPECIFICATIONS

- Voltage rating: 250V AC, DC
- Current rating: 7A, AC, DC
- Withstanding Voltage: 1500V AC/minute
- Insulation resistance: 1000MΩ min
- Temperature range: -40℃~+85℃
- Contact resistance: 10MΩ max

■ HOUSING

- Part No: H4201-2*NP
- Poles: 02-24
- Material: Nylon 66 UL94V-2

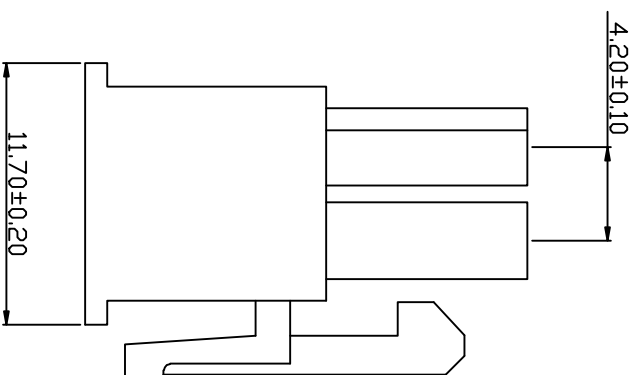
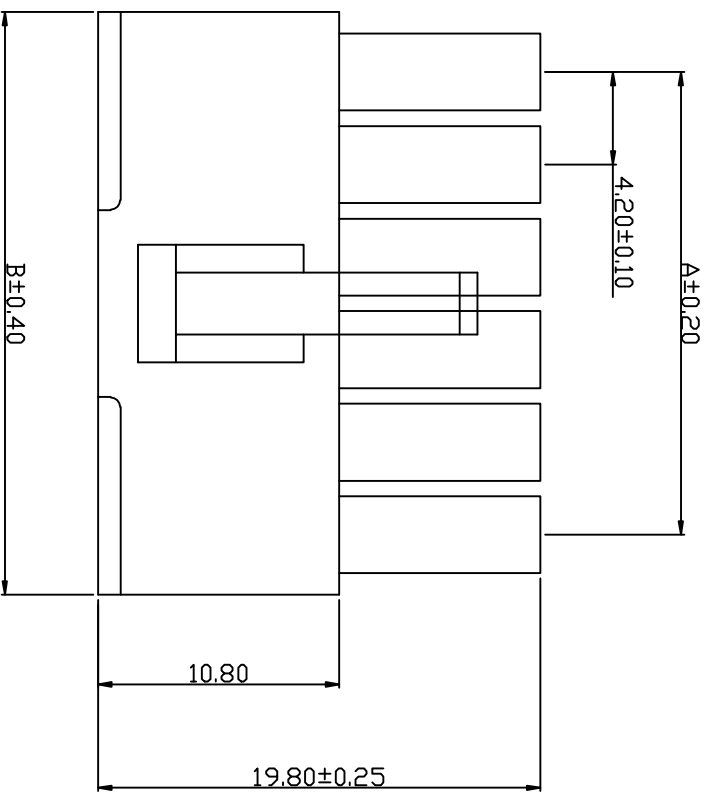

Part No	Dimensions (mm)	
	A	B
H4201-2*01	—	5.60
H4201-2*02	4.20	9.80
H4201-2*03	8.40	14.00
H4201-2*04	12.60	18.20
H4201-2*05	16.80	22.40
H4201-2*06	21.00	26.60
H4201-2*07	25.20	30.80
H4201-2*08	29.40	35.00
H4201-2*09	33.60	39.20
H4201-2*10	37.80	43.40
H4201-2*11	42.00	47.60
H4201-2*12	46.20	51.80

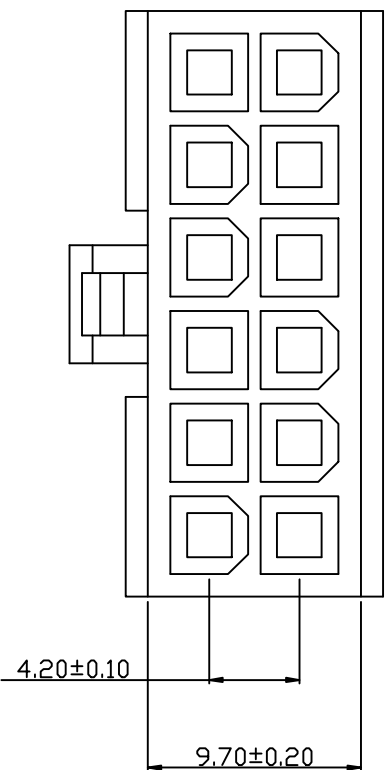

KLT 深圳市康利通电子科技有限公司

成品规格图

Tolerance

0±0.30

.0±0.25

.00±0.20

.000±0.015

TITLE	成品规格图		Tolerance	
CHECKED BY	DATE	SCALE	VER No	SIZE
2016-06-03	1:1		A	A4
DRAWN BY	UNIT:mm			
李国常	PART No	H4201-2*NP		

4

4

B

C

D

E

F

1