

B

C

E

公差表

REV	ECN NO	LOCATIONS	DESCRIPTION	DATE	CHANGER
A			新版本	2016-05-30	李国常

4

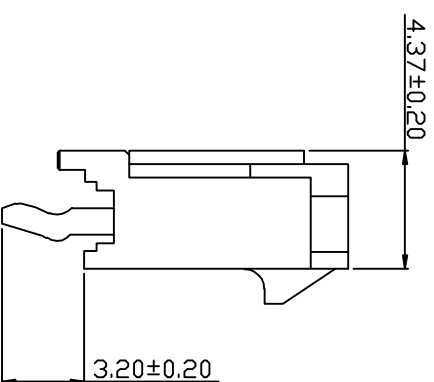
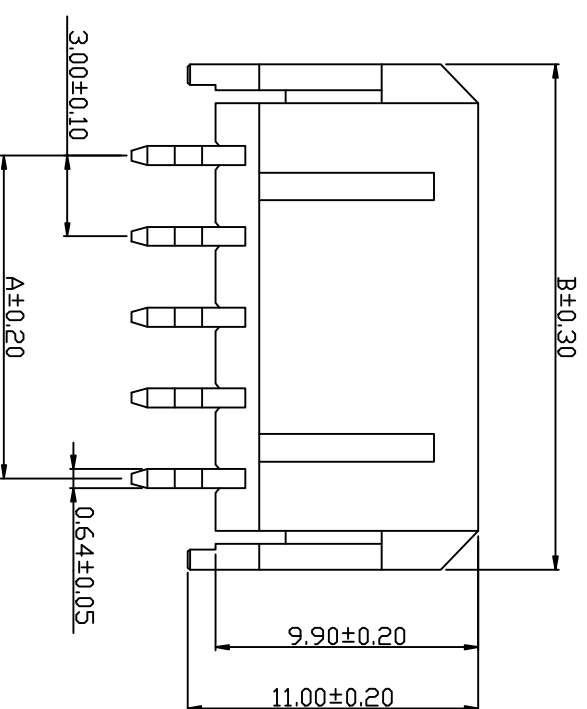
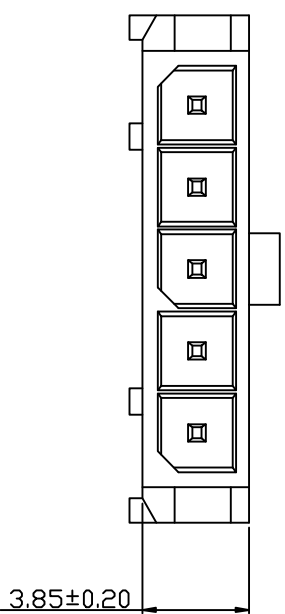

Part No	Dimensions (mm)	
	A	B
W3045V-02	3.00	9.65
W3045V-03	6.00	12.65
W3045V-04	9.00	15.65
W3045V-05	12.00	18.65
W3045V-06	15.00	21.65
W3045V-07	18.00	24.65
W3045V-08	21.00	27.65
W3045V-09	24.00	30.65
W3045V-10	27.00	33.65
W3045V-11	30.00	36.65
W3045V-12	33.00	39.65

- SPECIFICATIONS**
- Voltage rating: 250V AC, DC
  - Current rating: 5A, AC, DC
  - Withstanding Voltage: 1500V AC/minute
  - Insulation resistance: 1000MΩ min
  - Temperature range: -40℃~+85℃
  - Contact resistance: 10MΩ max
- WAFER**
- Part No: W3045V-NP
  - Poles: 02-12
  - Material: Nylon 46 UL94V-0
  - Pin Material: Brass /Tin-plated

4

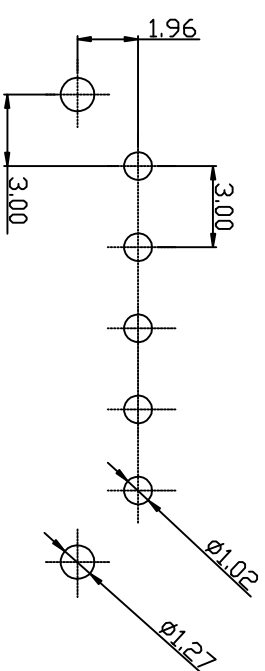

P.C.B LAYOUT

B

C

D

E

F

**KLT** 深圳市康利通电子科技有限公司

成品规格图

TOLERANCE

0±0.30

.0±0.25

.00±0.20

.000±0.015

1

TITLE	成品规格图		TOLERANCE	
CHECKED BY	DATE	SCALE	VER No	SIZE
	2016-05-30	1:1	A	A4
DRAWN BY	UNIT:mm			
李国常	PART No	W3045V-NP		

B

C

E

公差表

REV	ECN NO	LOCATIONS	DESCRIPTION	DATE	CHANGER
A			新版本	2016-05-30	李国常

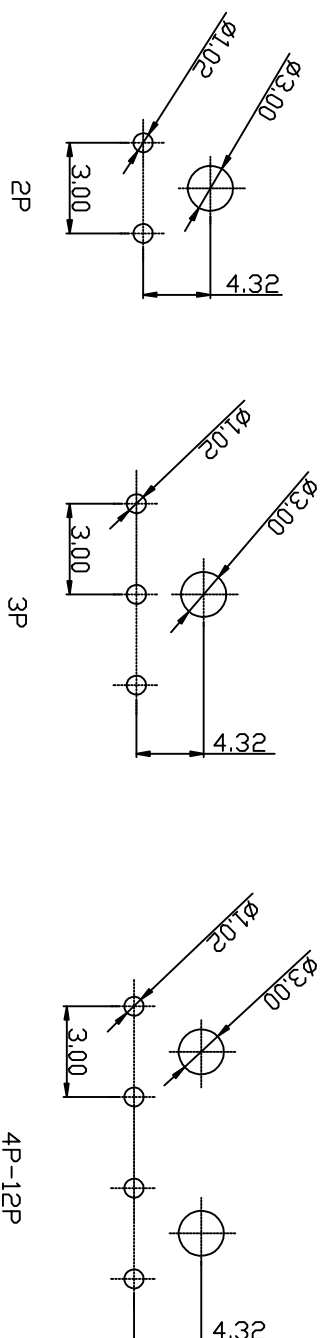

P.C.B LAYOUT

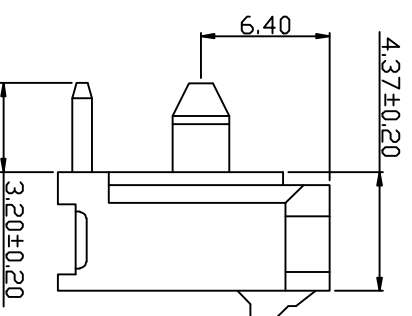
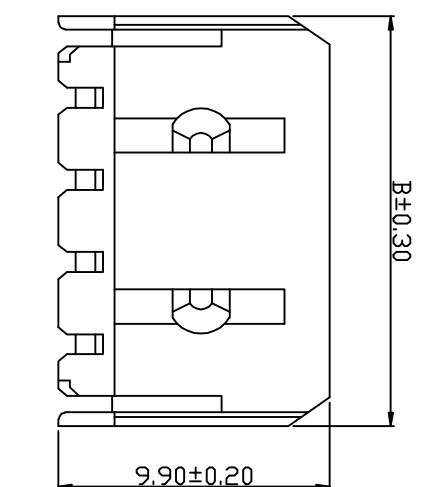

Part No	Dimensions (mm)	
	A	B
W304SR-02	3.00	9.65
W304SR-03	6.00	12.65
W304SR-04	9.00	15.65
W304SR-05	12.00	18.65
W304SR-06	15.00	21.65
W304SR-07	18.00	24.65
W304SR-08	21.00	27.65
W304SR-09	24.00	30.65
W304SR-10	27.00	33.65
W304SR-11	30.00	36.65
W304SR-12	33.00	39.65

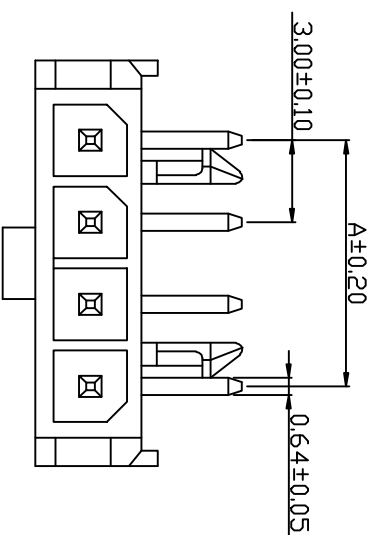

**KLT** 深圳市康利通电子科技有限公司

成品规格图

TOCERANCE

0±0.30

.0±0.25

.00±0.20

.000±0.015

VER No SIZE

A A4

TITLE	成品规格图		TOCERANCE	
CHECKED BY	DATE	SCALE	VER No	SIZE
DRAWN BY	UNIT:mm	1:1	A	A4
李国常	2016-05-30			
PART NO	W304SR-NP			

4

4

B

C

D

E

F

1

B

C

E

公差表

REV	ECN NO	LOCATIONS	DESCRIPTION	DATE	CHANGER
A			新版本	2016-05-30	李国常

4

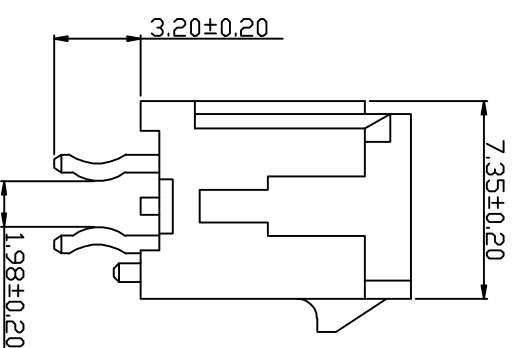
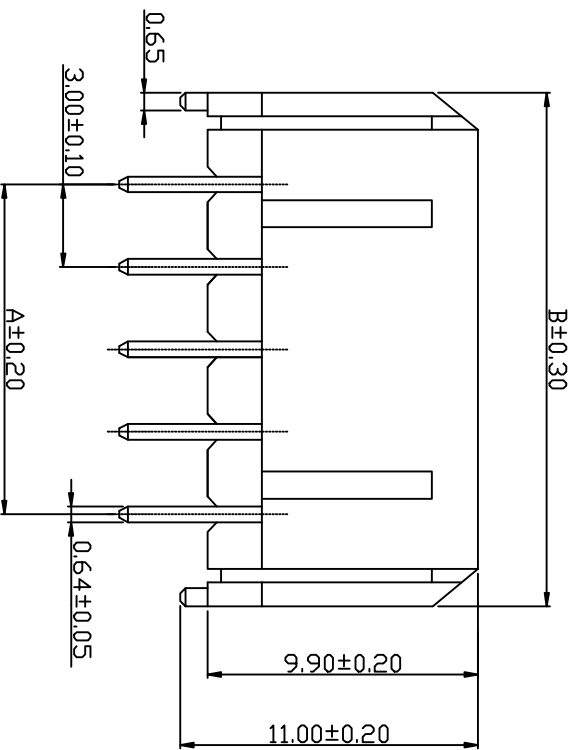
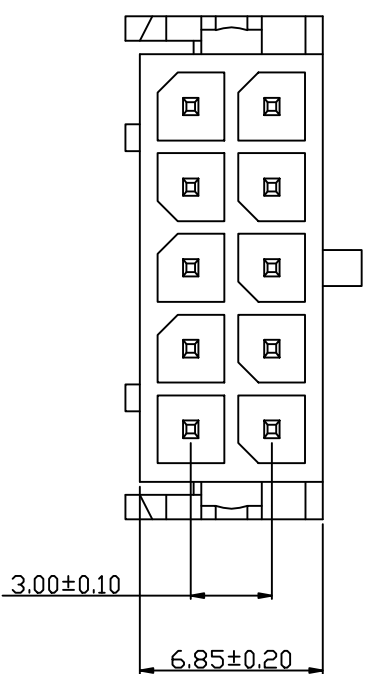

Part No	Dimensions (mm)	
	A	B
W3045V-2*01	—	6.65
W3045V-2*02	3.00	9.65
W3045V-2*03	6.00	12.65
W3045V-2*04	9.00	15.65
W3045V-2*05	12.00	18.65
W3045V-2*06	15.00	21.65
W3045V-2*07	18.00	24.65
W3045V-2*08	21.00	27.65
W3045V-2*09	24.00	30.65
W3045V-2*10	27.00	33.65
W3045V-2*11	30.00	36.65
W3045V-2*12	33.00	39.65

- SPECIFICATIONS**
- Voltage rating: 250V AC, DC
  - Current rating: 5A, AC, DC
  - Withstanding Voltage: 1500V AC/minute
  - Insulation resistance: 1000MΩ min
  - Temperature range: -40℃~+85℃
  - Contact resistance: 10MΩ max
- WAFER**
- Part No: W3045V-2\*NP
  - Poles: 02-24
  - Material: Nylon 66 UL94V-0
  - Pin Material: Brass /Tin-plated

4

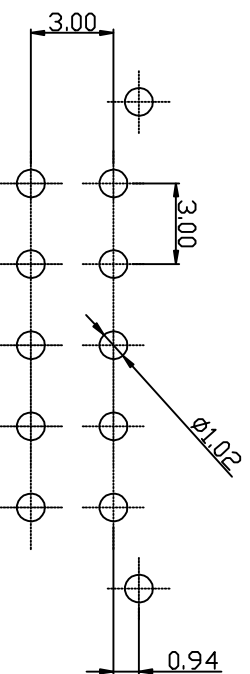

P.C.B LAYOUT

B

C

D

E

F

 <b>深圳市康利通电子科技有限公司</b>		T O C E R A N C E	
		0±0.30	
TITLE	成品规格图	.0±0.25	
CHECKED BY	DATE	SCALE	.000±0.015
	2016-05-30	1:1	VER No
DRAWN BY	UNIT:mm		SIZE
李国常	PART No	W3045V-2*NP	
		A	A4

1

