

B

C

E

公差表

REV	ECN NO	LOCATIONS	DESCRIPTION	DATE	CHANGER
A			新版本	2016-04-18	李国常

SPECIFICATIONS

- Voltage rating: 100V AC, DC
- Current rating: 1A, AC, DC
- Withstanding Voltage: 500V AC/minute
- Insulation resistance: 500MΩ min
- Temperature range: -40℃~+85℃
- Contact resistance: 20MΩ max

HOUSING

- Part No: H1500-NP
- Poles: 02-13
- Material: Nylon 66 UL94V-0

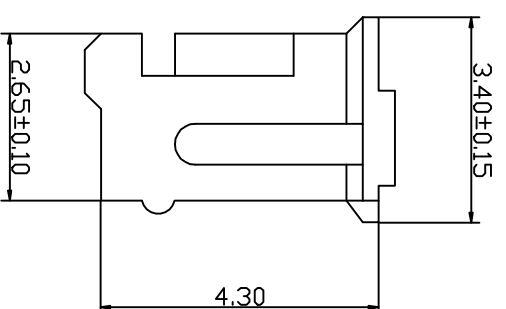
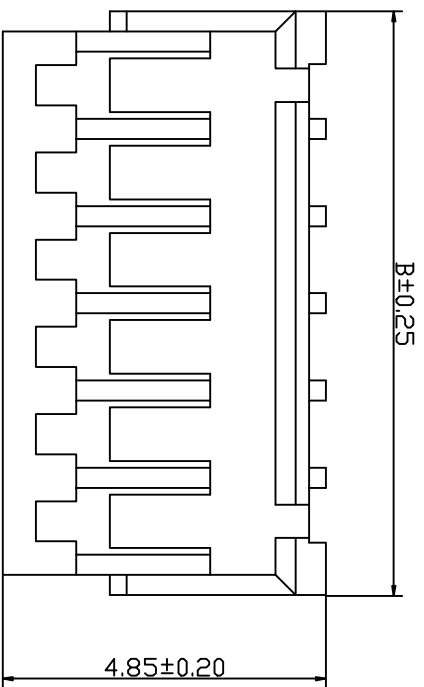

Part No	Dimensions (mm)	
	A	B
H1500-02	1.50	4.50
H1500-03	3.00	6.00
H1500-04	4.50	7.50
H1500-05	6.00	9.00
H1500-06	7.50	10.50
H1500-07	9.00	12.00
H1500-08	10.50	13.50
H1500-09	12.00	15.00
H1500-10	13.50	16.50
H1500-11	15.00	18.00
H1500-12	16.50	19.50
H1500-13	18.00	21.00

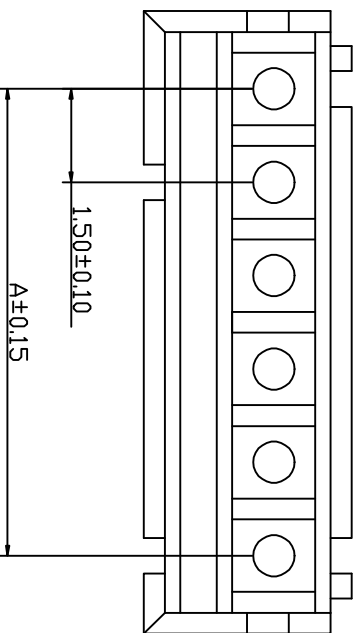

KLT 深圳市康利通电子科技有限公司

成品规格图

TOLERANCE

0±0.30

.0±0.25

.00±0.20

.000±0.015

TITLE	成品规格图		TOLERANCE	
CHECKED BY	DATE	SCALE	VER No	SIZE
DRAWN BY	UNIT:mm	1:1	A	A4
李国常	2016-04-18			
PART No	H1500-NP			

4

4

B

C

D

E

F

1

B

C

E

公差表

REV	ECN NO	LOCATIONS	DESCRIPTION	DATE	CHANGER
A			新版本	2016-04-18	李国常

SPECIFICATIONS

- Voltage rating: 100V AC,DC
- Current rating: 1A, AC, DC
- Withstanding Voltage: 500V AC/minute
- Insulation resistance: 500MΩ min
- Temperature range: -40℃~+85℃
- Contact resistance: 20MΩ max

HOUSING

- Part No: H1501-NP
- Poles: 02-13
- Material: Nylon 66 UL94V-0

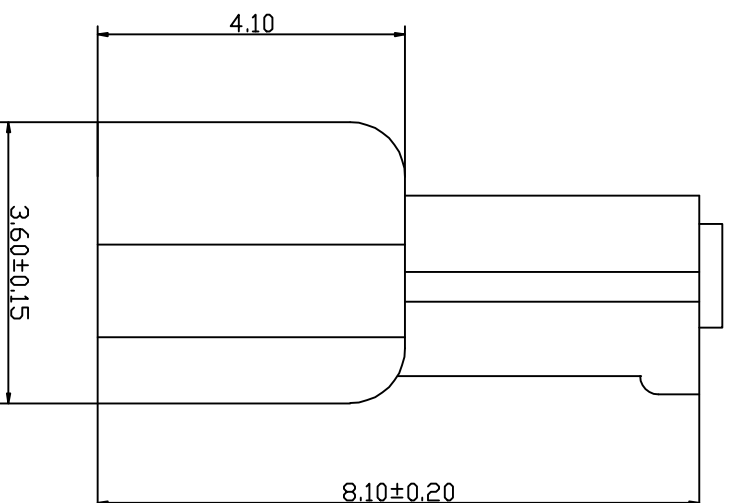
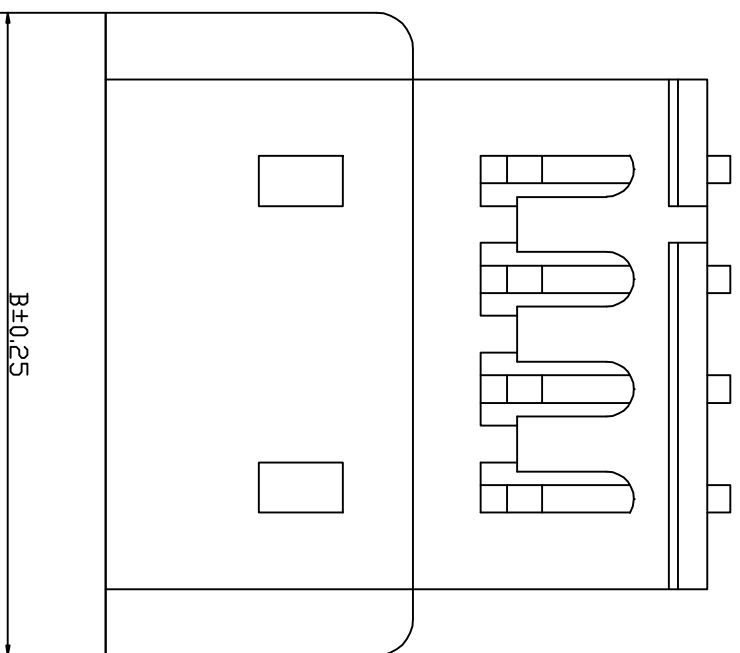

Part NO	Dimensions (mm)	
	A	B
H1501-02	1.50	5.50
H1501-03	3.00	7.00
H1501-04	4.50	8.50
H1501-05	6.00	10.00
H1501-06	7.50	11.50
H1501-07	9.00	13.00
H1501-08	10.50	14.50
H1501-09	12.00	16.00
H1501-10	13.50	17.50
H1501-11	15.00	19.00
H1501-12	16.50	20.50
H1501-13	18.00	22.00

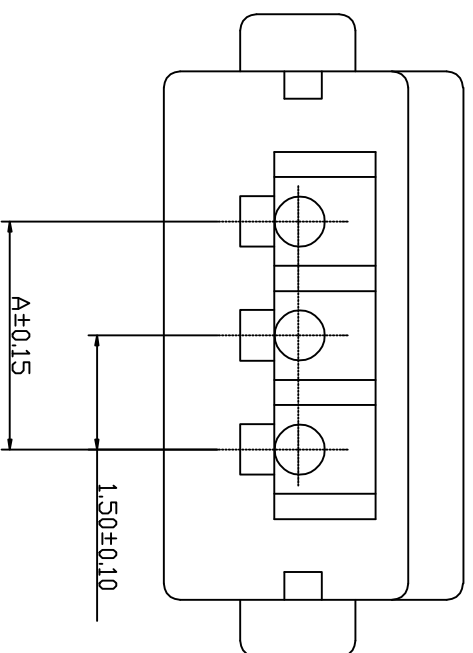

KLIT 深圳市康利通电子科技有限公司

成品规格图

TOLERANCE

0±0.30

.0±0.25

.00±0.20

.000±0.015

TITLE	成品规格图		TOLERANCE	
CHECKED BY	DATE	SCALE	VER No	SIZE
DRAWN BY	UNIT:mm	1:1	A	A4
李国常	2016-04-18			
PART NO	H1501-NP			

4

4

B

C

D

E

F

1

B

C

E

公差表

REV	ECN NO	LOCATIONS	DESCRIPTION	DATE	CHANGER
A			新版本	2016-04-18	李国常

4

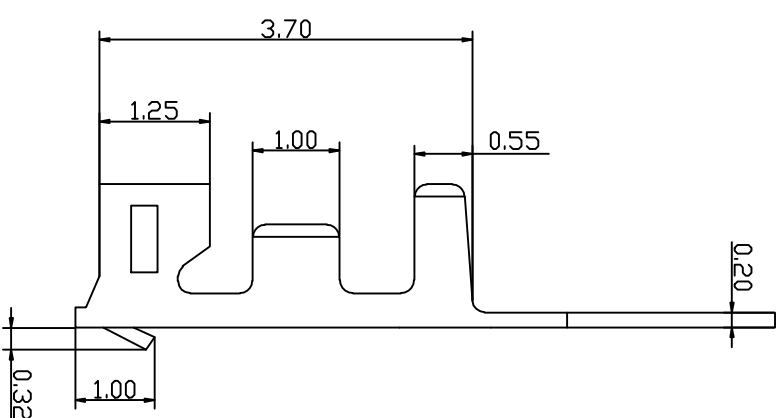
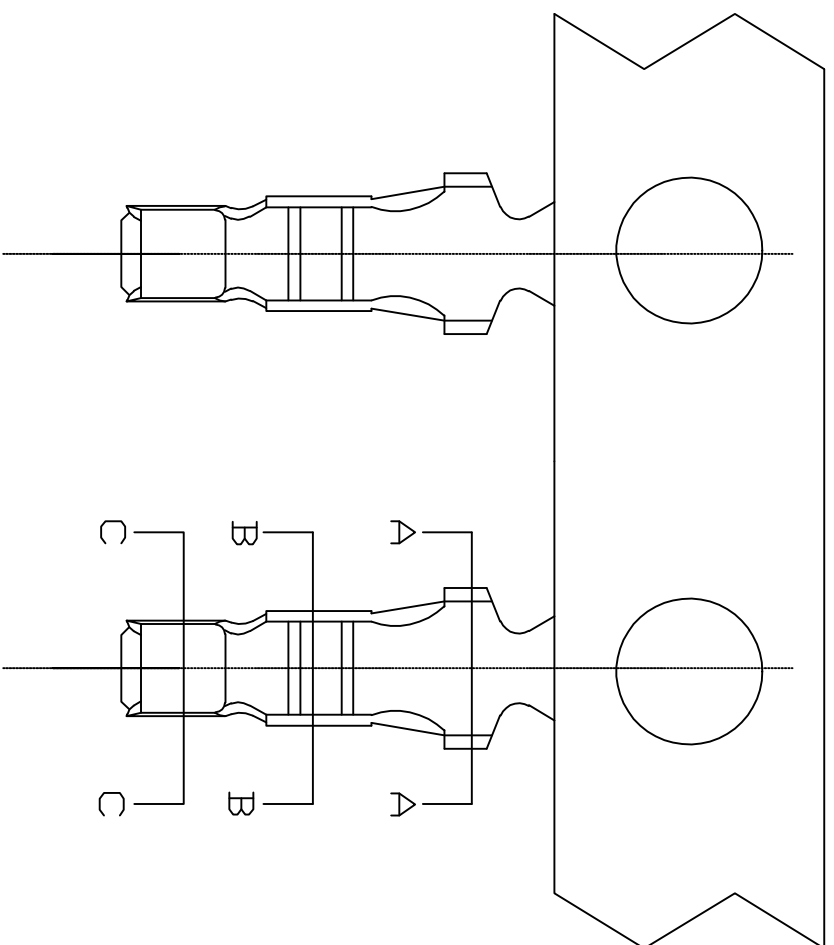

- SPECIFICATIONS**
- Voltage rating: 100V AC, DC
 - Current rating: 1A, AC, DC
 - Withstanding Voltage: 500V AC/minute
 - Insulation resistance: 500MΩ min
 - Temperature range: -40°C~+85°C
 - Contact resistance: 20MΩ max
- TERMINAL**
- Part No: T1500PT
 - Applicable wire: AWG#26-#32
 - Material: Phosphor Bronze
 - Finish: Tin Plated

SEC: A-A

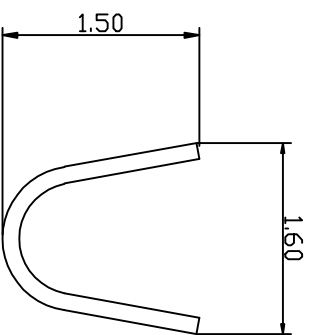

SEC: B-B

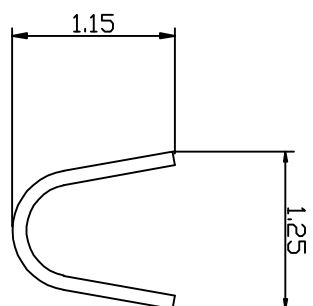

SEC: C-C

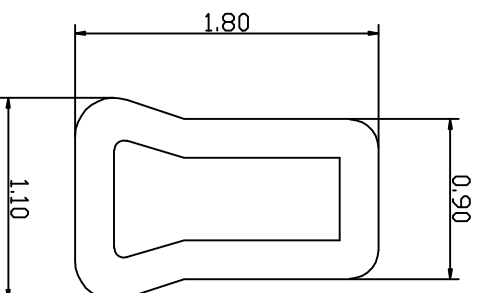

KLT 深圳市康利通电子科技有限公司

成品规格图

Tolerance

0±0.30

.0±0.25

.00±0.20

.000±0.015

1

TITLE

CHECKED BY

DATE 2016-04-18

DRAWN BY 李国常

UNIT:mm

SCALE 1:1

VER No A

SIZE A4

PART No

T1500PT

B

C

D

E

F

4

B

C

E

公差表

REV	ECN NO	LOCATIONS	DESCRIPTION	DATE	CHANGER
A			新版本	2016-04-18	李国常

4

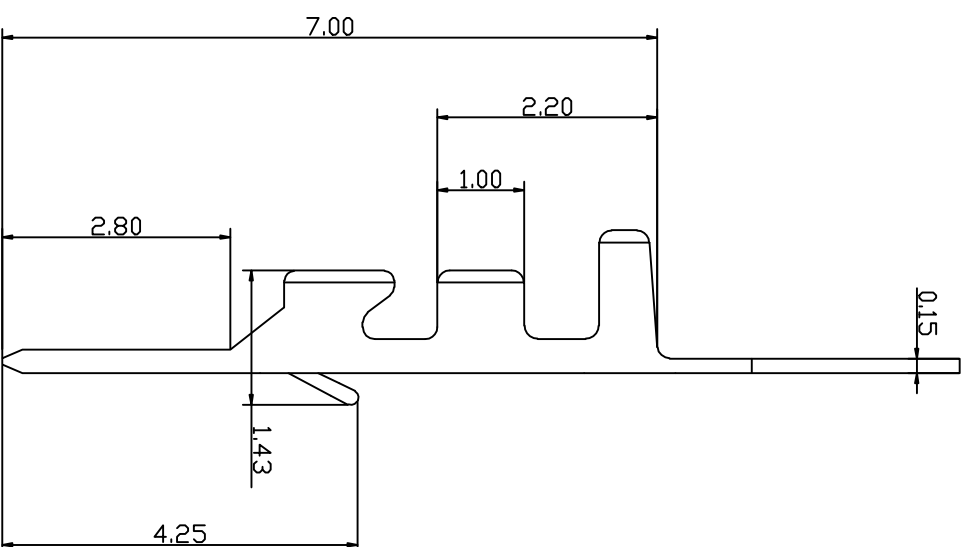
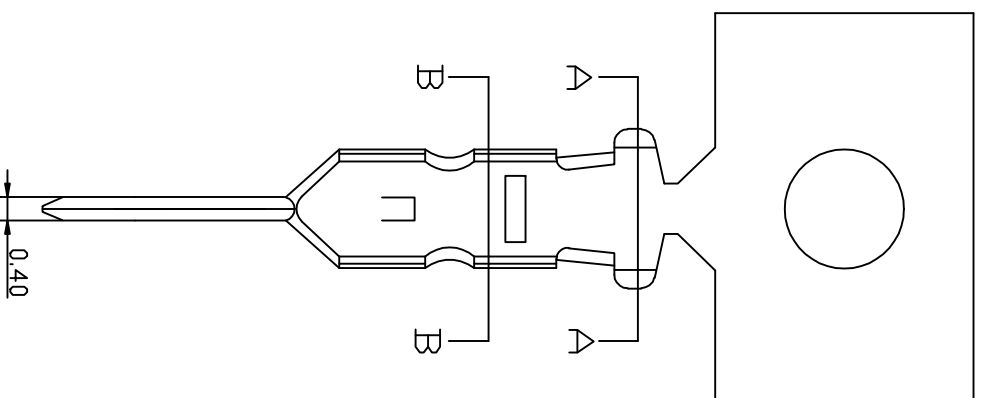

- SPECIFICATIONS**
- Voltage rating: 100V AC, DC
 - Current rating: 1A, AC, DC
 - Withstanding Voltage: 500V AC/minute
 - Insulation resistance: 500MΩ min
 - Temperature range: -40℃~+85℃
 - Contact resistance: 20MΩ max
- TERMINAL**
- Part No: T1501PT
 - Applicable wire: AWG#28-#32
 - Material: Phosphor Bronze
 - Finish: Tin Plated

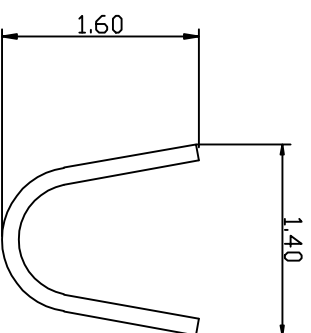

SEC: A-A

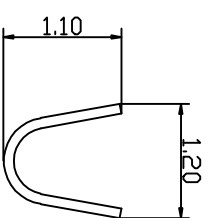

SEC: B-B

KLT 深圳市康利通电子科技有限公司

成品规格图

Tolerance

0±0.30

.0±0.25

.00±0.20

.000±0.015

1

TITLE	DATE	SCALE	VER No	SIZE
CHECKED BY	2016-04-18	1:1		
DRAWN BY	UNIT:mm		A	A4
DRAWN BY	PART No	T1501PT		

李国常

PART No

T1501PT

B

C

D

E

F

4

B

C

E

公差表

REV	ECN NO	LOCATIONS	DESCRIPTION	DATE	CHANGER
A			新版本	2016-04-18	李国常

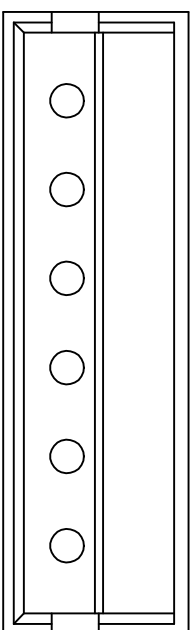

4

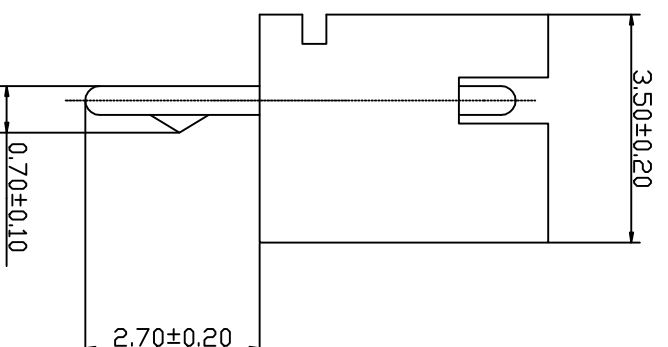
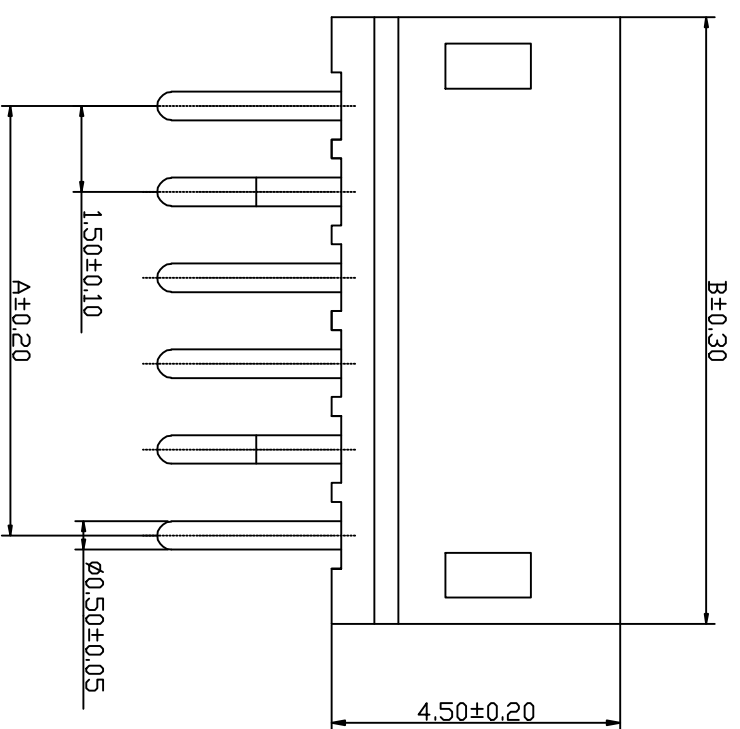

Part No	Dimensions (mm)	
	A	B
W1500V-02	1.50	4.50
W1500V-03	3.00	6.00
W1500V-04	4.50	7.50
W1500V-05	6.00	9.00
W1500V-06	7.50	10.50
W1500V-07	9.00	12.00
W1500V-08	10.50	13.50
W1500V-09	12.00	15.00
W1500V-10	13.50	16.50
W1500V-11	15.00	18.00
W1500V-12	16.50	19.50
W1500V-13	18.00	21.00

- SPECIFICATIONS**
- Voltage rating: 50V AC, DC
 - Current rating: 1A, AC, DC
 - Withstanding Voltage: 500V AC/minute
 - Insulation resistance: 500MΩ min
 - Temperature range: -40°C~+85°C
 - Contact resistance: 10MΩ max
- WAFER
- Part No: W1500V-NP
 - Poles: 02-13
 - Material: Nylon 66 UL94V-0
 - Pin Material: Brass /Tin-plated

4

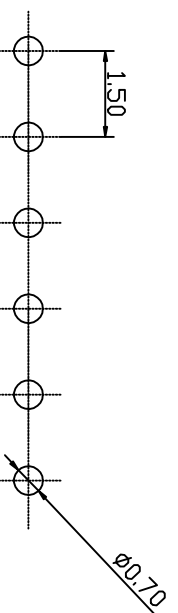

P.C.B LAYOUT

B

C

D

E

F

KLT 深圳市康利通电子科技有限公司

成品规格图

TOLERANCE

0±0.30

.0±0.25

.00±0.20

.000±0.015

VER No SIZE

A A4

1

TITLE	成品规格图		TOLERANCE	
CHECKED BY	DATE	SCALE	VER No	SIZE
	2016-04-18	1:1	A	A4
DRAWN BY	UNIT:mm	W1500V-NP		
李国常	PART No			

B

C

E

公差表

REV	ECN NO	LOCATIONS	DESCRIPTION	DATE	CHANGER
A			新版本	2016-04-18	李国常

4

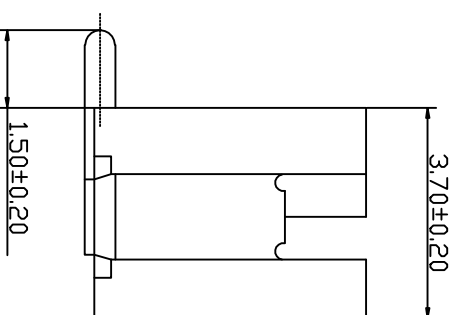
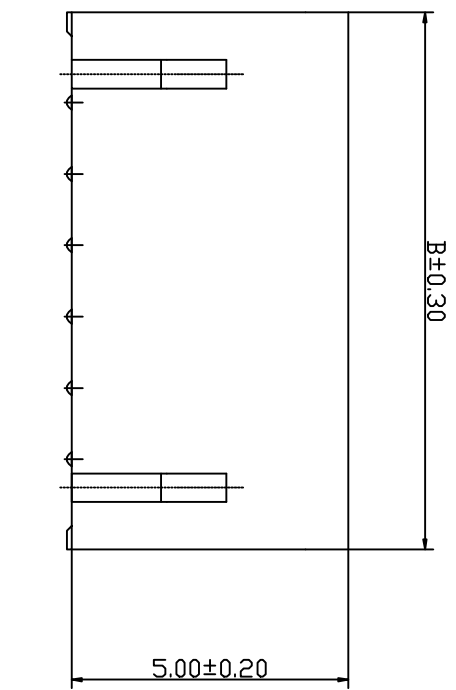
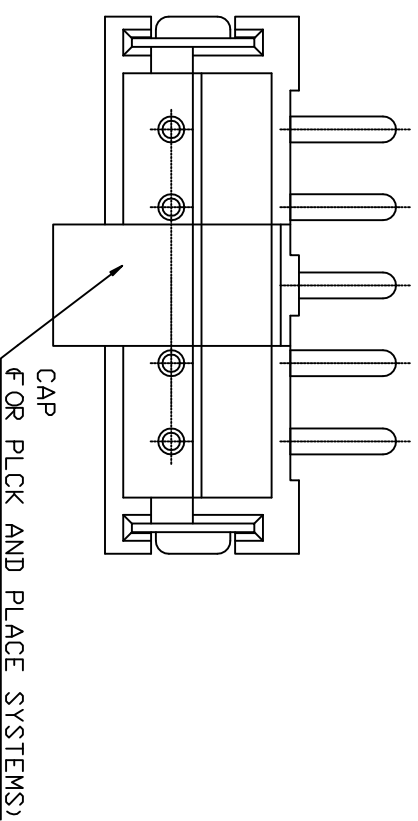
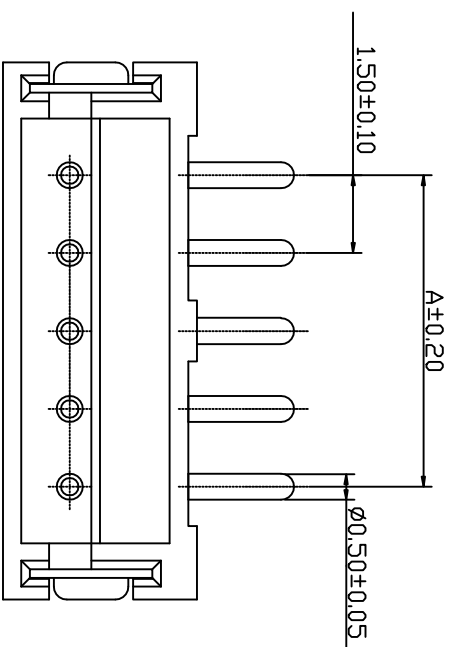

Part No	Dimensions (mm)	
	A	B
W1500SV-02	1.50	6.00
W1500SV-03	3.00	7.50
W1500SV-04	4.50	9.00
W1500SV-05	6.00	10.50
W1500SV-06	7.50	12.00
W1500SV-07	9.00	13.50
W1500SV-08	10.50	15.00
W1500SV-09	12.00	16.50
W1500SV-10	13.50	18.00
W1500SV-11	15.00	19.50
W1500SV-12	16.50	21.00
W1500SV-13	18.00	22.50

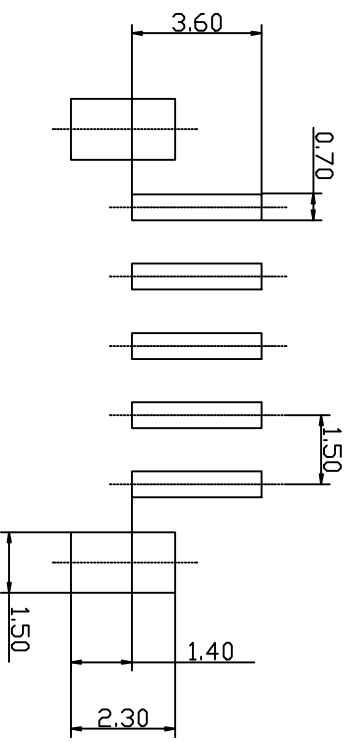

P.C.B LAYOUT

KLT 深圳市康利通电子科技有限公司

成品规格图

TOLERANCE

0±0.30

.0±0.25

.00±0.20

.000±0.015

VER No SIZE

A A4

TITLE	成品规格图		SCALE		1:1	VER No	SIZE
CHECKED BY	DATE	2016-04-18	SCALE	1:1	VER No	SIZE	
DRAWN BY	UNIT:mm				A	A4	
李国常	PART NO	W1500SV-NP					

B

C

D

E

F

4

1

B

C

E

公差表

REV	ECN NO	LOCATIONS	DESCRIPTION	DATE	CHANGER
A			新版本	2016-04-18	李国常

4

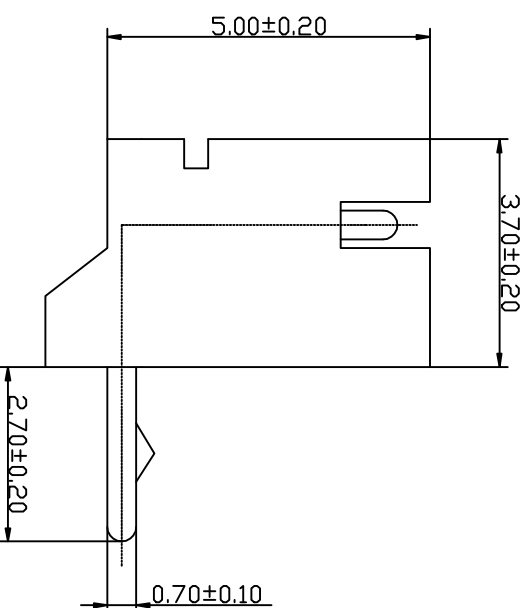
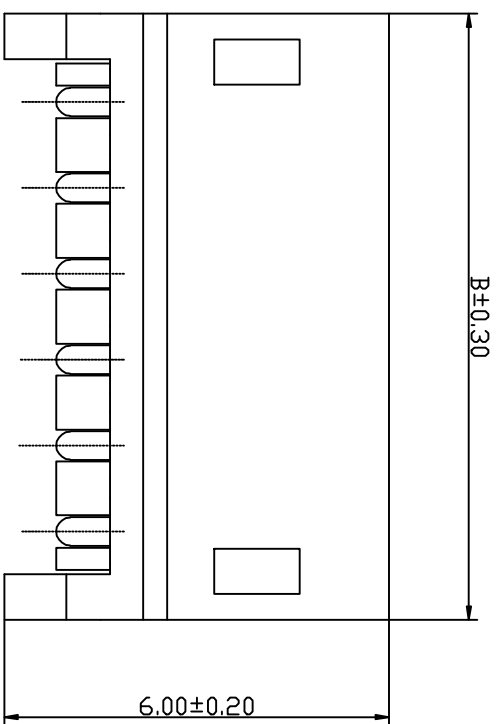
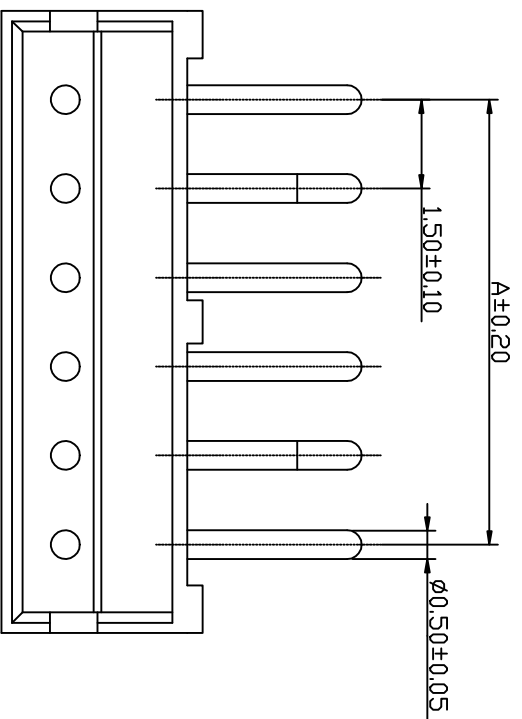

Part No	Dimensions (mm)	
	A	B
W1500R-02	1.50	4.50
W1500R-03	3.00	6.00
W1500R-04	4.50	7.50
W1500R-05	6.00	9.00
W1500R-06	7.50	10.50
W1500R-07	9.00	12.00
W1500R-08	10.50	13.50
W1500R-09	12.00	15.00
W1500R-10	13.50	16.50
W1500R-11	15.00	18.00
W1500R-12	16.50	19.50
W1500R-13	18.00	21.00

- SPECIFICATIONS**
- Voltage rating: 50V AC, DC
 - Current rating: 1A, AC, DC
 - Withstanding Voltage: 500V AC/minute
 - Insulation resistance: 500MΩ min
 - Temperature range: -40°C~+85°C
 - Contact resistance: 10MΩ max
- WAFER**
- Part No: W1500R-NP
 - Poles: 02-13
 - Material: Nylon 66 UL94V-0
 - Pin Material: Brass /Tin-plated

4

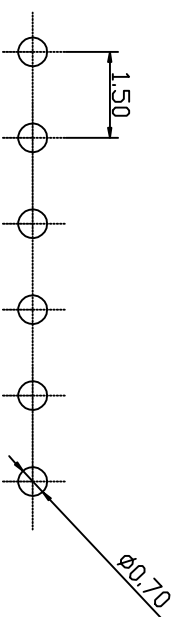

P.C.B LAYOUT

B

C

D

E

F

KLT 深圳市康利通电子科技有限公司

TOLERANCE

0±0.30

.0±0.25

.00±0.20

.000±0.015

VER No SIZE

A A4

1

TITLE	成品规格图		TOLERANCE	
CHECKED BY	DATE	SCALE	VER No	SIZE
DRAWN BY	UNIT:mm	1:1	A	A4
李国常	2016-04-18			
PART No	W1500R-NP			

B

C

E

公差表

REV	ECN NO	LOCATIONS	DESCRIPTION	DATE	CHANGER
A			新版本	2016-04-18	李国常

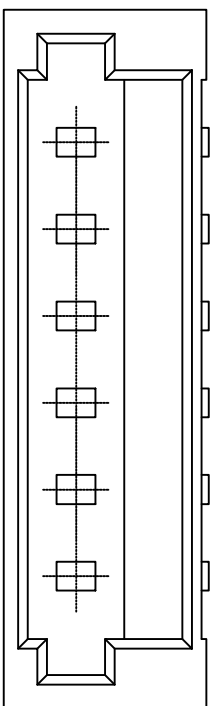

4

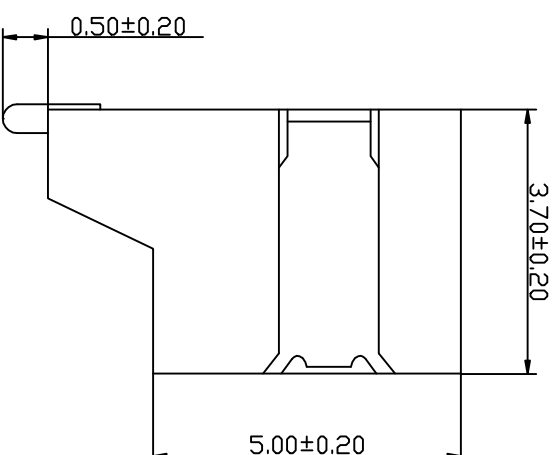
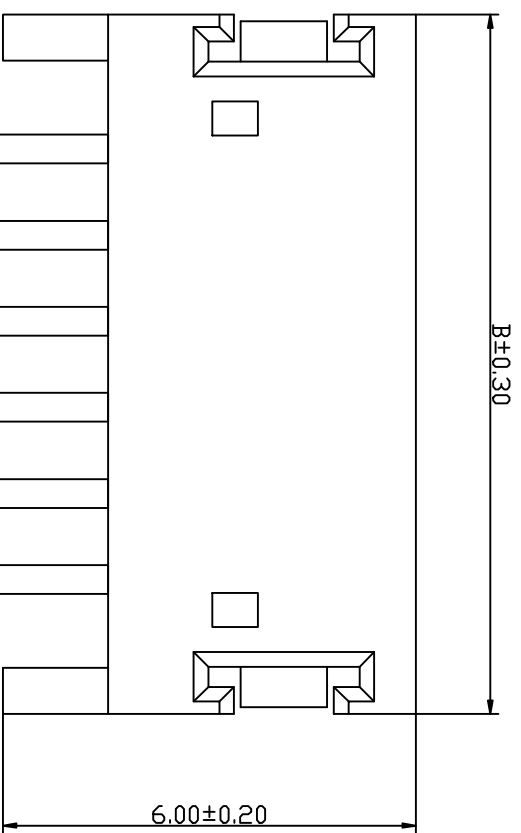

4

SPECIFICATIONS

- Voltage rating: 50V AC, DC
 - Current rating: 1A, AC, DC
 - Withstanding Voltage: 500V AC/minute
 - Insulation resistance: 500MΩ min
 - Temperature range: -40°C~+85°C
 - Contact resistance: 10MΩ max
- WAFER
- Part No: W1500SR-NP
 - Poles: 02-13
 - Material: Nylon 6T UL94V-0
 - Pin Material: Brass /Tin-plated
 - Ter Material: Phosphor Bronze /Tin-plated

Part No	Dimensions (mm)	
	A	B
W1500SR-02	1.50	6.00
W1500SR-03	3.00	7.50
W1500SR-04	4.50	9.00
W1500SR-05	6.00	10.50
W1500SR-06	7.50	12.00
W1500SR-07	9.00	13.50
W1500SR-08	10.50	15.00
W1500SR-09	12.00	16.50
W1500SR-10	13.50	18.00
W1500SR-11	15.00	19.50
W1500SR-12	16.50	21.00
W1500SR-13	18.00	22.50

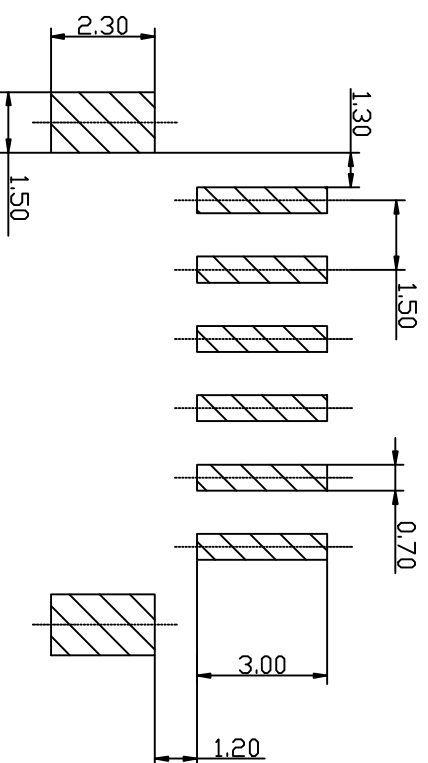

P.C.B LAYOUT

B

C

D

E

F

KLT 深圳市康利通电子科技有限公司

成品规格图

TOCERANCE

0±0.30

.0±0.25

.00±0.20

.000±0.015

TITLE	成品规格图		TOCERANCE	
CHECKED BY	DATE	SCALE	VER No	SIZE
	2016-04-18	1:1	A	A4
DRAWN BY	UNIT:mm			
李国常				
PART NO	W1500SR-NP			

1

B

C

E

公差表

REV	ECN NO	LOCATIONS	DESCRIPTION	DATE	CHANGER
A			新版本	2016-04-18	李国常

4

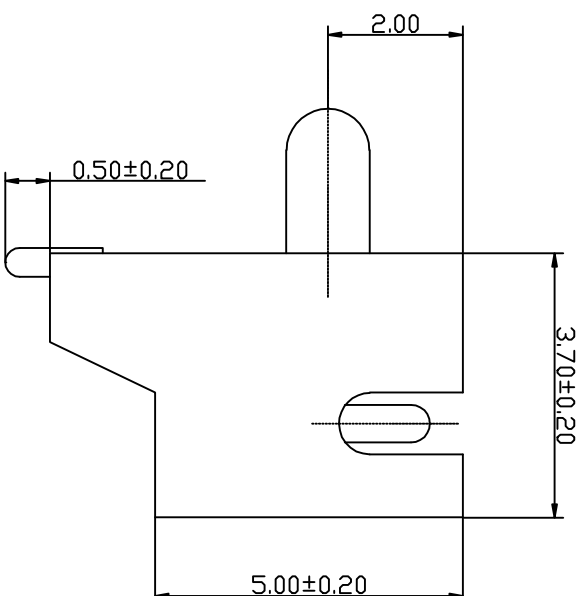
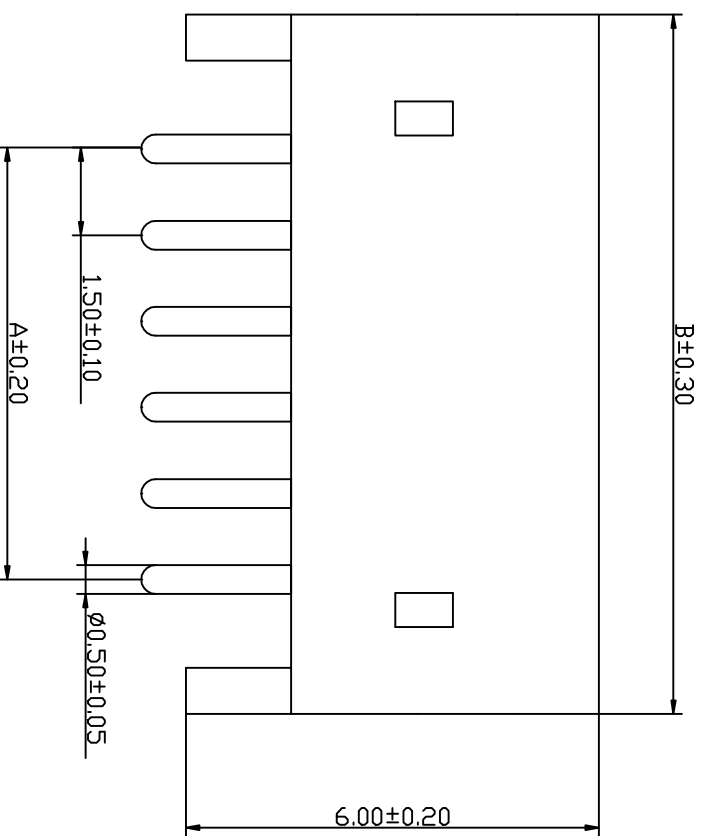
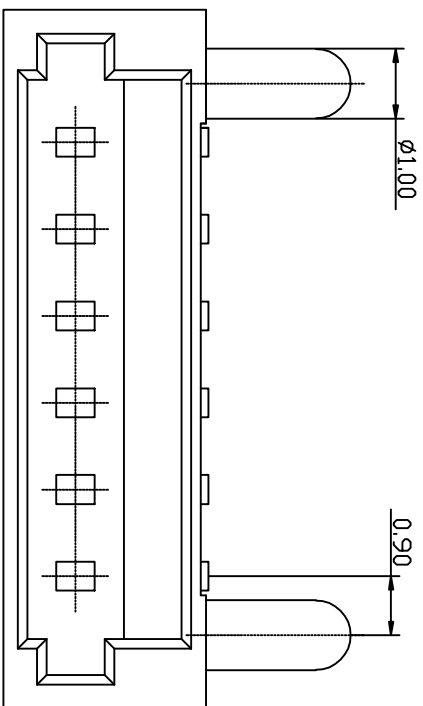

Part No	Dimensions (mm)	
	A	B
W1500SR-02-1	1.50	6.00
W1500SR-03-1	3.00	7.50
W1500SR-04-1	4.50	9.00
W1500SR-05-1	6.00	10.50
W1500SR-06-1	7.50	12.00
W1500SR-07-1	9.00	13.50
W1500SR-08-1	10.50	15.00
W1500SR-09-1	12.00	16.50
W1500SR-10-1	13.50	18.00
W1500SR-11-1	15.00	19.50
W1500SR-12-1	16.50	21.00
W1500SR-13-1	18.00	22.50

- SPECIFICATIONS**
- Voltage rating: 50V AC, DC
 - Current rating: 1A, AC, DC
 - Withstanding Voltage: 500V AC/minute
 - Insulation resistance: 500MΩ min
 - Temperature range: -40℃~+85℃
 - Contact resistance: 10MΩ max
- WAFER
- Part No: W1500SR-NP-1
 - Poles: 02-13
 - Material: Nylon 6T UL94V-0
 - Pin Material: Brass /Tin-plated

4

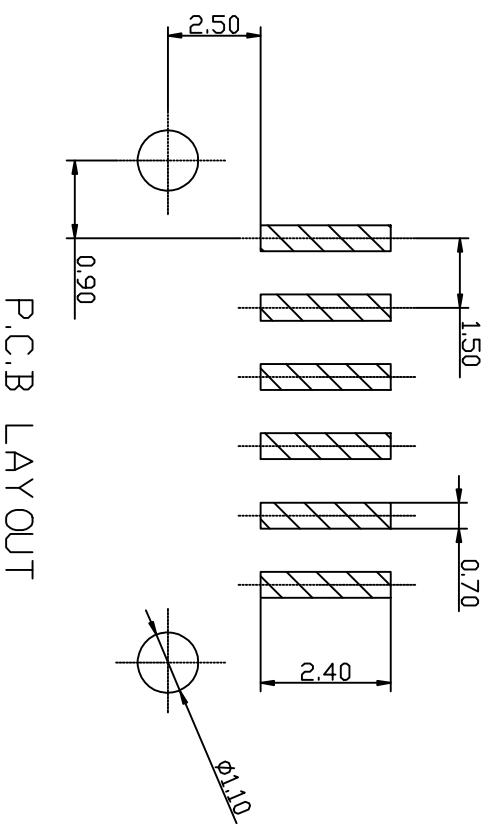

P.C.B LAYOUT

KLT 深圳市康利通电子科技有限公司

成品规格图

TOLERANCE

0±0.30

.0±0.25

.00±0.20

.000±0.015

VER No SIZE

A A4

TITLE	成品规格图		TOLERANCE	
CHECKED BY	DATE	SCALE	VER No	SIZE
DRAWN BY	UNIT:mm	1:1	A	A4
李国常	2016-04-18			
PART No	W1500SR-NP-1			

B

C

D

E

F

1

B

C

E

公差表

REV	ECN NO	LOCATIONS	DESCRIPTION	DATE	CHANGER
A			新版本	2016-04-18	李国常

4

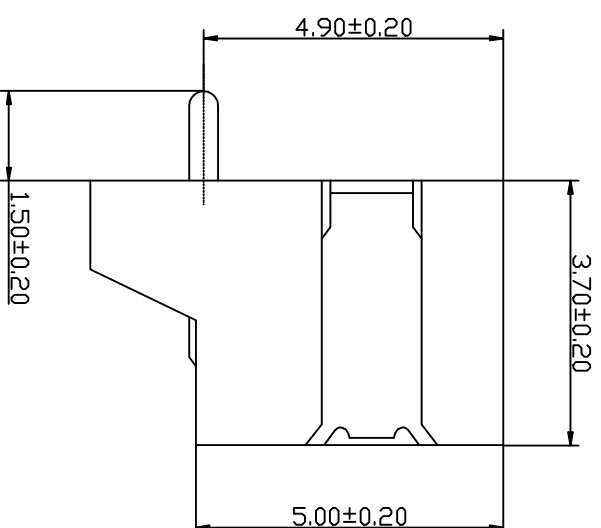
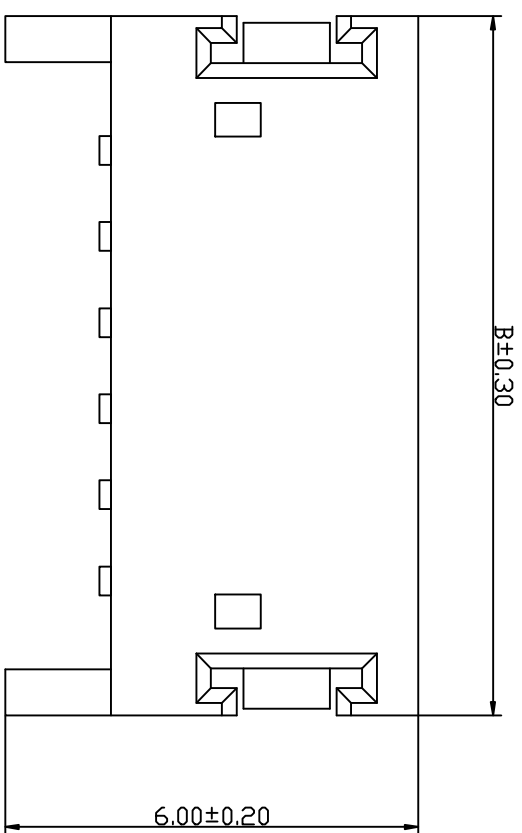
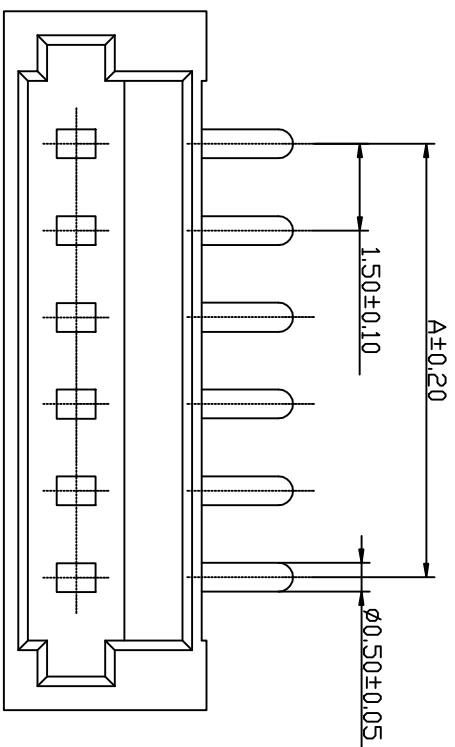

Part No	Dimensions (mm)	
	A	B
W1500SR-02-2	1.50	6.00
W1500SR-03-2	3.00	7.50
W1500SR-04-2	4.50	9.00
W1500SR-05-2	6.00	10.50
W1500SR-06-2	7.50	12.00
W1500SR-07-2	9.00	13.50
W1500SR-08-2	10.50	15.00
W1500SR-09-2	12.00	16.50
W1500SR-10-2	13.50	18.00
W1500SR-11-2	15.00	19.50
W1500SR-12-2	16.50	21.00
W1500SR-13-2	18.00	22.50

- SPECIFICATIONS**
- Voltage rating: 50V AC, DC
 - Current rating: 1A, AC, DC
 - Withstanding Voltage: 500V AC/minute
 - Insulation resistance: 500MΩ min
 - Temperature range: -40°C~+85°C
 - Contact resistance: 10MΩ max
- WAFER
- Part No: W1500SR-NP-2
 - Poles: 02-13
 - Material: Nylon 6T UL94V-0
 - Pin Material: Brass /Tin-plated
 - Ter Material: Phosphor Bronze /Tin-plated

4

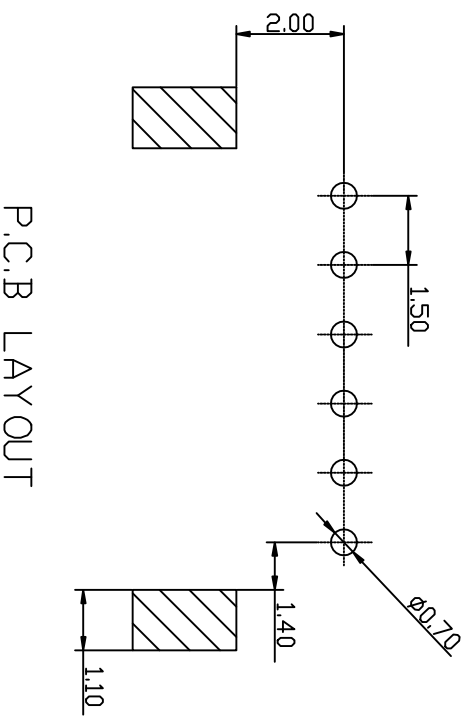

P.C.B LAYOUT

KLT 深圳市康利通电子科技有限公司

成品规格图

TOCERANCE

0±0.30

.0±0.25

.00±0.20

.000±0.015

TITLE	成品规格图		SCALE		VER No		SIZE	
CHECKED BY	DATE	SCALE	1:1	VER No	SIZE			
2016-04-18								
DRAWN BY	UNIT:mm	A		A4				
李国常								
PART No	W1500SR-NP-2							

B

C

D

E

F

1